

DIMENSIONS :- METRIC (INCH)

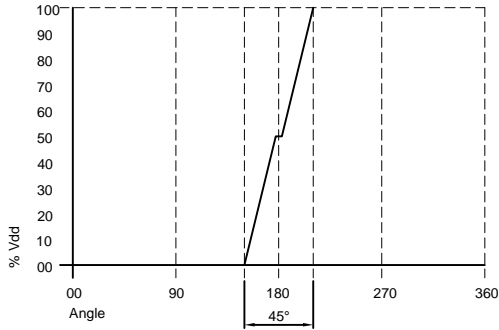

OUTPUT CHARACTERISTICS GRAPH

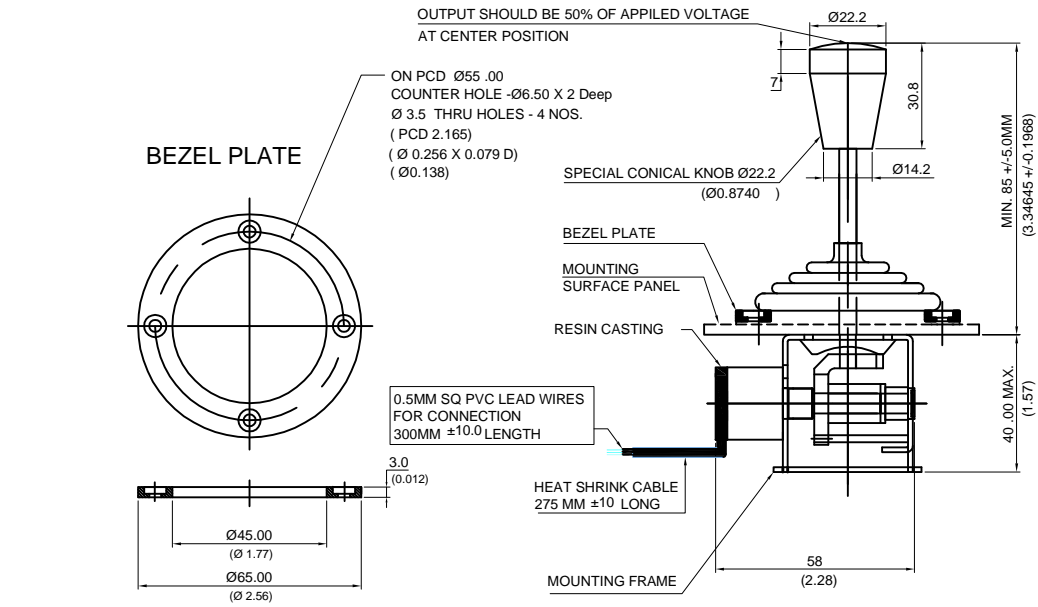
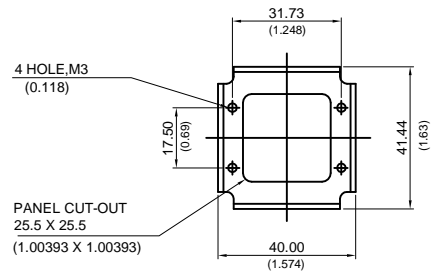

ELECTRICAL CHARACTERISTICS :-	UNITS	VALUE
ELECTRICAL ANGLE...	DEGREES	45°±5°
ELECTRICAL DEAD ZONE...	DEGREES	5°
MOVEMENT OF STICK...	DEGREES	25 - 0 - 25
OPRATING INPUT VOLTAGE RANGE...	Vdc	5 ±0.5
OUTPUT VOLTAGE...	Vdc	0 to 5
STANDARD INDEPENDENT LINEARITY TOLERANCE...(IEC 393)..	±%	1.0
RESOLUTION...	%	0.025 of Vdd
REVERSE VOLTAGE PROTECTION...	Vdc	-12 (Breakdown at -14)
OVER VOLTAGE...	Vdc	24 Max.
OUTPUT CURRENT...	mA	30 Max.
OUTPUT LOAD...	K	4.7 Min. 10 TYPICAL
SUPPLY CURRENT...	mA	10 Max.
DIELECTRIC STRENGTH...	V rms	750
INSULATION RESISTANCE...	M	1000
ELECTROSTATIC DISCHARGE (ESD)...	Kv	2
ENVIRONMENTAL CHARACTERISTICS		
OPERATING TEMPERATURE...	DEGREE C	-40 TO +125
ROHS COMPLIANCE...	--	YES
PERFORMANCE...		
LIFE ...	NO OF CYCLE	5,000,000
MATERIAL OF CONSTRUCTION:-		
HOUSING...	--	ALUMINIUM ANODIZED
SHAFT...	--	STAINLESS STEEL
TERMINAL...	--	7/38 MULTI STRANDS TEFLON WIRE (4WIRE'S)
MOUNTING FACILITY...	--	FRAME & S.S. PLATE WITH M3 CSK HOLES
RUBBER BOOT...	--	NITRIAL RUBBER...
MOUNTING FLANGE...	--	STAINLESS STEEL...



**CONTACT LESS
JOYSTICK CONTROLLER**

MODEL CLJ-101 (xxx)
(SINGLE AXIS)

FIRST ISSUE : 07/05/2015

SCALE : 1:1

TOLERANCES
DIN ISO 2768-1 (1991-08)
(TOLERANCE CLASS-MEDIUM)

PART NO.
U 169xxx

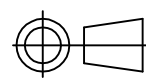

CUSTOMER DRAWING REF NO
NA

REV - 00

CUSTOMER :- UAPL STANDARD

SHEET:-1 Of 1